

Buffalopumps

BUFFALO CAN-O-MATIC® II

Reliable Zero Leakage Pumps

Some advantages:

- 1) Conical bearings - takes thrust, compensates for wear and keeps rotor centered
- 2) Sealed stator can - No leaks !
- 3) Precise machined fit at casing and backplate fits - No leaks !
- 4) Standard electrical connection

www.serviceprocess.net

Service Process Equipment, Inc.

PO Box 850908

Mobile AL 36685-0908

251.342.1313•Fax 251.342.1377

Email msellers@serviceprocess.net



Background

The Can-O-Matic II is a hermetically sealed zero leakage pump with an ANSI standard pump end and a motor with unique tapered spring-loaded wear-compensating bearings.

This specialized bearing construction provides a high level of reliability. When operating, pump axial and radial thrust loads within a Can-O-Matic II are balanced, and bearings wear concentrically. Elliptical wear patterns that cause stator-can rupture, as in failure prone sleeve bearing designs, are controlled. Under normal or near-normal operating conditions, a periodic inspection (usually annually) of the Can-O-Matic II bearing system is suggested to insure trouble-free, reliable operation. In liquid handling systems where severe pressure or temperature transients may occur, or suction pressures vary dramatically resulting in "zero" NPSH available to a Can-O-Matic II pump, vibration monitors or proximity probes should be utilized to avoid catastrophic failure due to massive axial thrust forces.

To confirm the built-in reliability of the Can-O-Matic II design, each unit is thoroughly tested before shipment. Each pumping unit is given a hydrostatic test to insure the integrity of materials... a running test to insure performance capability... and a halogen/mass spectrometer test to insure that the complete unit is hermetically sealed.

It is worth noting the fact that the Buffalo Can-O-Matic II is engineered and manufactured to ANSI Standards. This provides an efficient, low NPSH pump design that is field repairable and easily maintained.

The Buffalo Can-O-Matic II design has been field-proven in thousands of installations, and is backed by 30 years of experience in handling toxic, corrosive and carcinogenic liquids, refrigerants, high temperature water and heat transfer liquids.

Availability/Service

The Can-O-Matic II is a part of Buffalo's "PDQ" Quick Shipment Program, where most popular model pumps are available for short-term shipment. In addition, a complete pump repair service is provided for Buffalo Pump customers.

Engineering Assistance

Buffalo Pumps Sales Engineers throughout the United States have the engineering training and practical field experience necessary for the correct selection and application of Can-O-Matic II Pumps. In addition, they have the full support of Buffalo's home office research and engineering personnel. This in-depth engineering service is vital to assure proper pump application, especially when handling difficult and/or possibly hazardous fluids.

General Pump Specifications

Pump Sizes	13
Gpm	1500
Head	700'
Rpm	1750 & 3500

Working Pressure to 400 psi standard. Higher pressure 600 psi designs available.

Temperature range from -100°F to 250°F standard, -150°F to 400°F available.

Materials of Construction

PART NO.	DUCTILE IRON CAST IRON FITTED	DUCTILE IRON BRONZE FITTED	DUCTILE IRON 316SS FITTED	ALL 316SS
2 CASING	D.I.	D.I.	D.I.	316SS
3 IMPELLER	C.I.	BRZ	316SS	316SS
9 CASING RING		CARBON GRAPHITE		
10 MOTOR RING		CARBON GRAPHITE		
202 MOTOR FLANGE	316SS	316SS	316SS	316SS
205 BEARING HOUSING		316 STAINLESS STEEL		
208 WEAR RING HOUSING	316SS	316SS	316SS	316SS
247 BEARINGS		CARBON GRAPHITE		
211 JOURNALS		316SS HARD FACED TO 500 BRINELL		
216 STATOR CAN		HASTELLOY C		
221 ROTOR CAN		316 STAINLESS		
229 ROTOR SHAFT		316 STAINLESS		
250 SPRINGS		316 STAINLESS		
258 THRUST-O-MATIC ORIFICE		316 STAINLESS		

General Motor Specifications

- Totally enclosed liquid cooled design
- Hastelloy C Stator Can
- 316SS Rotor and Rotor Can
- Class C Insulation System
- Hardened bearing journals
- Thermal sensor
- Liquid tight conduit box with oil expansion dome and pressure relief valve set at 15 PSI
- Dielectric oil filled stator housing

Motor Horsepower Capability

Frame	RPM	
	1750	3500
66M	5 HP	7½ HP
66V	10	15
66ZF	20	25
215ZH	30	40
256ZM	50	60
256AB	75	100

Copyright 2001
Buffalo Pumps

THE CAN-O-MATIC II CONCEPT

Standard Electrical Connections

Keeps Rotor Centered !

No Leaks !

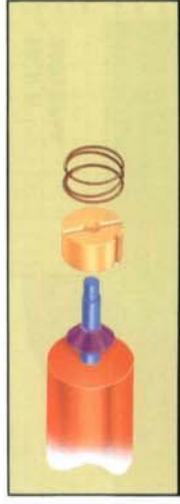

Conical Bearings
Long bearing life is essential for extended trouble-free service. Can-O-Matic II features a patented, self-adjusting spring loaded conical type of bearing which assures concentric rotation, eliminating mechanical interference between the rotor can and stator can. These bearings, of carbon graphite, maintain correct bearing/journal fit at all times.



Balanced Axial Thrust
Buffalo's exclusive Thrust-O-Matic® device, consisting of this precision sized orifice and tapered motor shaft end, combines with the impeller balance chamber arrangement to create and maintain equilibrium between stationary and rotating elements.

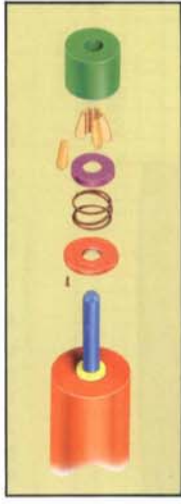

Segmented Bearings
Larger motors, which produce greater radial loads, are fitted with tapered segmented carbon graphite bearings. These tapered bearings, which are spring loaded, compensate for wear and prevent mechanical interference between the rotor can and stator can.

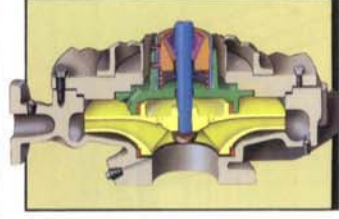

Reduced Radial Thrust
Can-O-Matic II pump casings have a special volute design which minimizes radial thrust, contributing to extended bearing life. Single and double volute casings are utilized, depending on pump size.

Stator Can
To insure leakproof integrity, the stator can is a heliarc welded Hastelloy C assembly. At the pump end, the can is welded to the pump adapter flange. At the other end, it is welded to the bearing cap.

Rotor Can
The rotor can, of 316SS, is heliarc welded to the rotor end plates which are welded to the shaft. Bearing shaft journals are of 316SS hard faced to 500 Brinell.

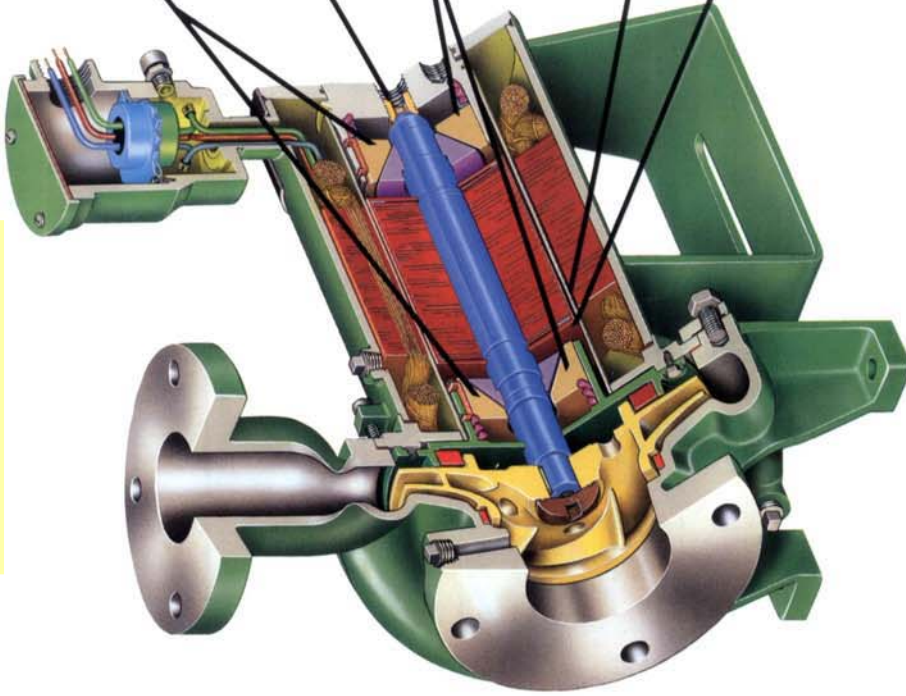



Performance Data

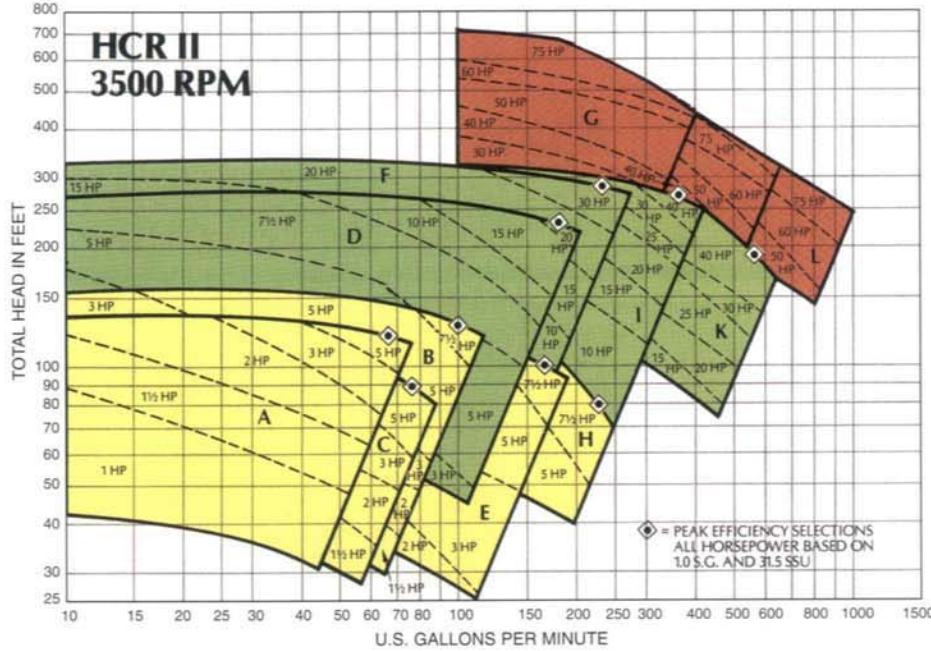

Performance Identification	Pump Identification	Pump Size Discharge x Suction x Impeller Dia.
A	1015-6	1 x 1½ x 6
B	AA6	1 x 1½ x 6
C	1025-6	1 x 2½ x 6
D	058	2 x 1 x 8
E	AB6	1½ x 3 x 6
F	509	1½ x 3 x 9
G	2013	1½ x 3 x 13
H	106	2 x 3 x 6
I	609	2 x 3 x 9
J	3013	2 x 3 x 13
K	709	3 x 4 x 9
L	4013	3 x 4 x 13
M	8013	4 x 6 x 13

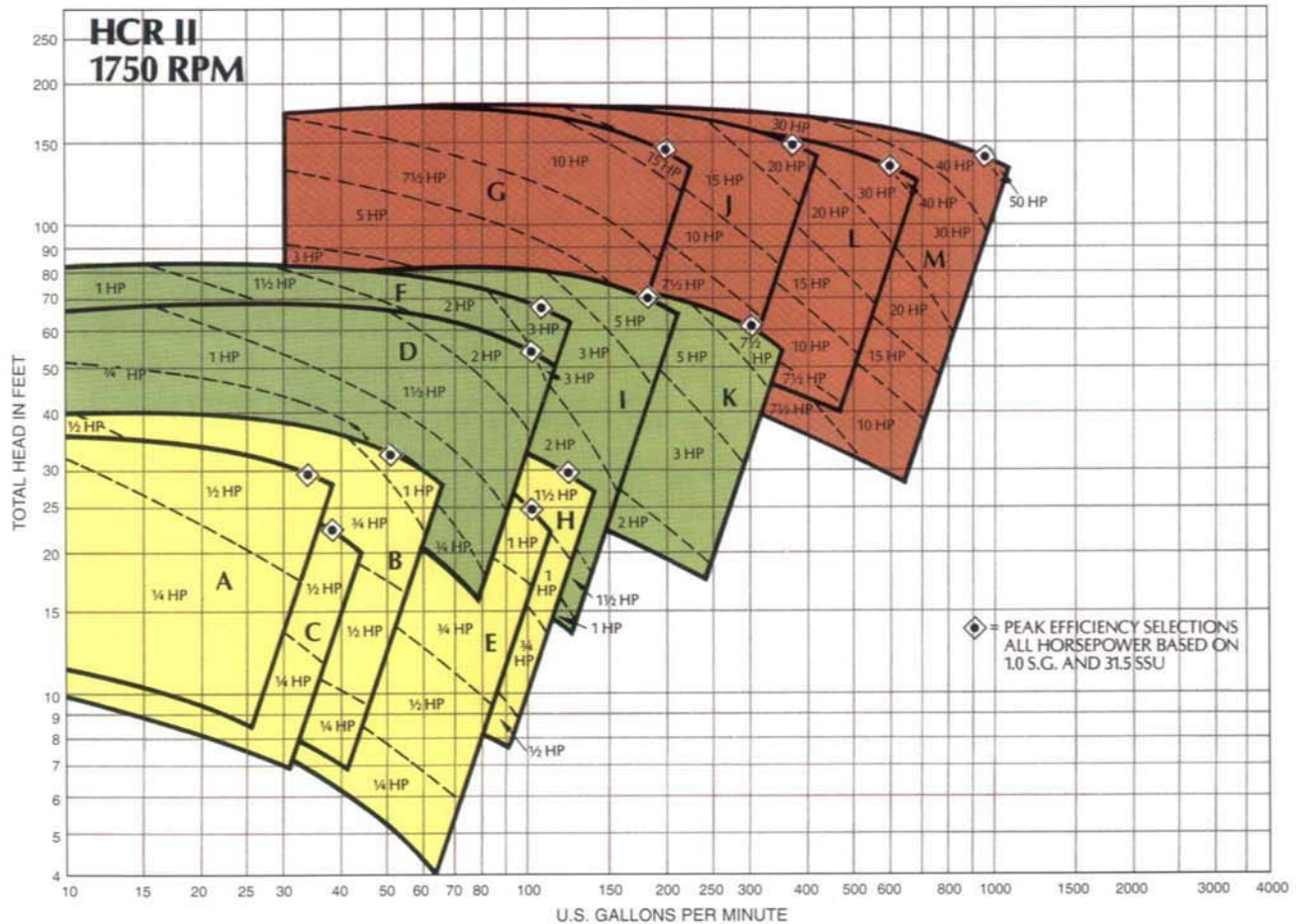

Dimensions

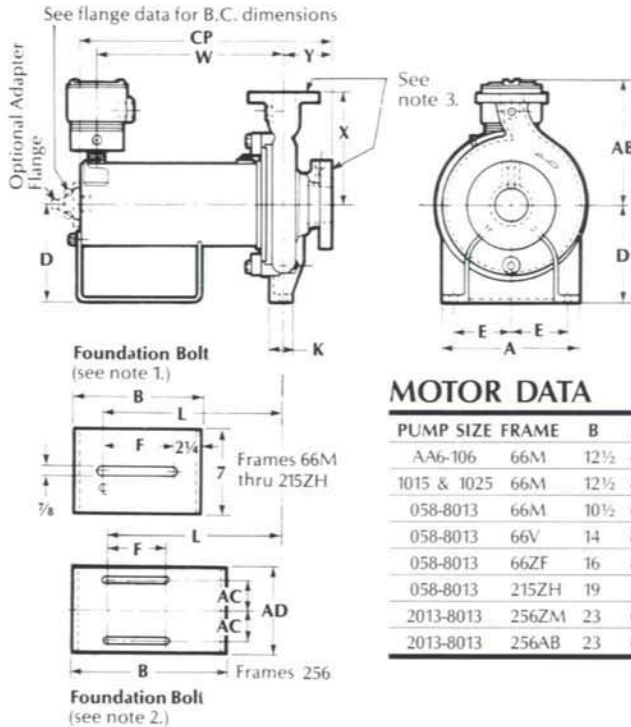

- NOTES:**
1. Allowance for back withdrawal. Unit may be rotated 90° to the right or left.
 2. Allowance for back withdrawal.
 3. Suction flanges are tapped on 3013, 4013, and 8013 size pumps, also on 1015 and 1025 size pumps
- † For frames 256AB

MOTOR DATA

PUMP SIZE	FRAME	B	F	L	W	CP	AB	AC	AD
AA6-106	66M	12½	4	10 ⁹ / ₁₆	14 ¹⁵ / ₁₆	20 ³ / ₈	10 ⁷ / ₈	NA	NA
1015 & 1025	66M	12½	4	11 ³ / ₈	15¼	19 ¹ / ₁₆	10 ⁷ / ₈	NA	NA
058-8013	66M	10½	6	12 ⁷ / ₁₆	13 ¹³ / ₁₆	19½	10 ⁷ / ₈	NA	NA
058-8013	66V	14	8	13 ¹⁵ / ₁₆	15 ¹³ / ₁₆	21½	10 ⁷ / ₈	NA	NA
058-8013	66ZF	16	8	15 ¹⁵ / ₁₆	19 ¹³ / ₁₆	25½	10 ⁷ / ₈	NA	NA
058-8013	215ZH	19	10	17 ¹⁵ / ₁₆	22 ¹³ / ₁₆	28½	11 ¹¹ / ₁₆	NA	NA
2013-8013	256ZM	23	6	20½	24 ⁹ / ₁₆	31 ³ / ₁₆	12¼	7	15½
2013-8013	256AB	23	6	20½	28 ⁷ / ₁₆	34 ¹¹ / ₁₆	12¼	7	15½

PUMP DATA

PUMP SIZE	SUCTION x DISCHARGE	A	D	E	K	X	Y
AA6	1½ x 1	8	5¼	3	2	6½	4
AB6	3 x 1½	8	5¼	3	2	6½	4
106	3 x 2	8	5¼	3	2	8¼	4
10-5	1½ x 1	NA	NA	NA	2	6	1⅝
1025	2½ x 1	NA	NA	NA	2	6	1⅝
12515	1½ x 1¼	NA	NA	NA	2	7	2
058	2 x 1	11¼	8¼	4⅞	1 ¹⁵ / ₁₆	8½	4
509	3 x 1½	11¼	8¼	4⅞	1 ¹⁵ / ₁₆	8½	4
609	3 x 2	11¼	8¼	4⅞	1 ¹⁵ / ₁₆	9½	4
709	4 x 3	11¼	8¼	4⅞	1 ¹⁵ / ₁₆	11	4
2013	3 x 1½	11¼	10	4⅞	2 ¹ / ₁₆	10½	4
3013	3 x 2	11¼	10	4⅞	2 ¹ / ₁₆	11½	4
4013	4 x 3	11¼	10	4⅞	2 ¹ / ₁₆	12½	4
8013	6 x 4	14	10	6	2 ¹ / ₁₆	13½	4

FLANGE DATA

SIZE	O.D.	T'KNS.	NO. HOLES (NOTE 4, 5 & 6)	FLG. B.C.	OPT. AD'PT. FLG. ° HLS.	FLG. B.C.
1	4¼	⅝	4-⅝	3⅝	4-⅝-11 UNC	2¼
1¼	4⅞	⅝	4-⅝	3⅝	4-⅝-11 UNC	2¼
1½	5	11/16	4-⅝ DR. 4-⅝-13 UNC	3⅝	4-⅝-11 UNC	2¼
2	6	¼	4-⅝	4⅞	4-⅝-11 UNC	2¼
2½	7	⅞	4-⅝ DR. 4-⅝-11 UNC	5½	4-⅝-11 UNC	2¼
3	7½	15/16	4-⅝	6	4-⅝-11 UNC	2¼
3	7½	15/16	4-⅝ DR. 4-⅝-11 UNC	6	4-⅝-11 UNC	2¼ 3¼†
4	9	1	8-⅝ DR. 8-⅝-11 UNC	7½	4-⅝-11 UNC	2¼† 3¼†
6	11	1⅝	8-⅝ DR. 8-⅝-10 UNC	9½	4-⅝-11 UNC	2¼† 3¼†

Buffalopumps

874 Oliver Street
 North Tonawanda, New York 14120-3298
 Phone: 716-693-1850
 Fax: 716-693-6303
 Web Site: www.buffalopumps.com



ACCREDITED BY
 THE DUTCH
 COUNCIL FOR
 CERTIFICATION



ACCREDITED BY
 THE DUTCH
 COUNCIL FOR
 CERTIFICATION